



POLIFILM

PIONEERING **LASER PROTECTION FILM**

FOR FIBRE AND CO₂ LASERS

EXCELLENCE IN FILMS

ASSURED PERFORMANCE SUPERIOR PROTECTION FILM

LASER USE IN SHEET PROCESSING

Laser cutting systems offer high efficiency with maximum precision, which is one reason why they are firmly established and widely used in the processing of sheet materials. Modern high performance CO₂ and fibre laser machines work efficiently on a wide variety of raw materials such as Carbon Steels, Aluminium and Stainless Steels alike. Processing is quick, flexible and extremely accurate. This makes them the ideal choice for cutting Stainless Steel with high quality surface finishes, having a brushed steel finish or high gloss polish, they characterise the design of modern refrigerators, sinks, kitchen equipment and more.

Challenges faced in pursuit of perfection.

To obtain perfect results, a few hurdles have to be overcome in the production process. Processes such as pressing, handling and other associated material operations carry potential risks for the appearance of the end product. There are also aspects of the laser cutting process itself that present risks to the finished component. If those points are not addressed properly, they can lead to a significantly higher rejection rate. During the cutting process, sparks inevitably occur which can contaminate or even damage the surface finish. To avoid surface deterioration, the application of a temporary protection film is vitally important. At first glance it may appear to be a small and unimportant part of a highly complex industrial production process, but in reality, the surface protection film is a genuinely high-tech product itself.

Complex technology. Advanced solutions.

An explanation of the mechanisms of modern laser cutting equipment explains why. A critical factor affecting the

cutting result is the concentration of the laser beam which must be precisely focused on the cutting point. (Figure 1).

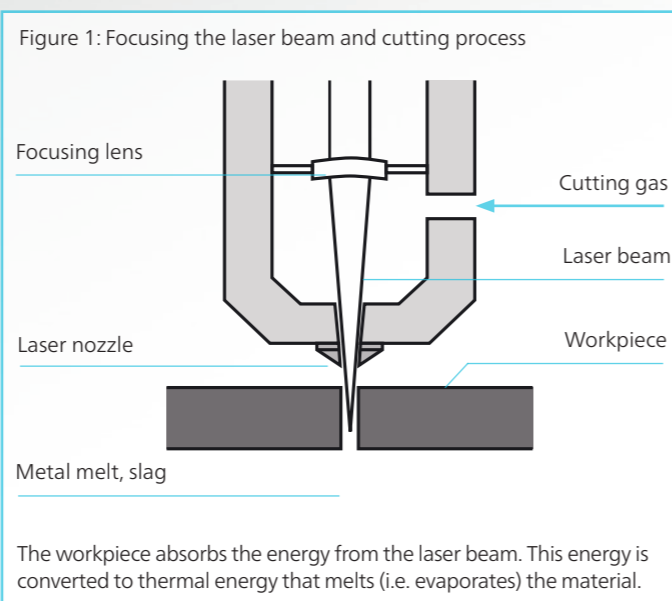

The smallest deviations can cause wastage and even damage the cutting head. The absorption rate of the material to be cut (Figure 2) also plays an essential role in the overall performance. The laser light and the focus of the beam are aligned to enable as much energy as possible to be absorbed by the product, which is crucial for a fast and clean cut.

Reflected laser light generates precisely the opposite. It reduces both the speed and performance of the cutting system and the quality of the cut itself.

A protective film applied to the sheet material must not

hamper the process (Figure 3). It should, as close as possible, match the absorption level of the material to be cut. At the same time the film should provide reliable and effective protection for the high quality surface finish.

Laser cutting without compromise.

POLIFILM PROTECTION have CO₂ and fibre laser film solutions which meet all of these requirements and more. The film allows the laser beam to cut through the specially developed polyethylene films together with the sheet material simultaneously. The result: no need for pre-cutting. The optimised adhesive strength prevents bubbling at the pierce point continuing throughout the cut, the adhesion is matched precisely to the finish of the material preventing damage throughout the entire cutting process. After processing, the protection film is removed easily and cleanly without leaving any residues behind. The significant advantage of POLIFILM PROTECTION laser films are in their performance: The laser cutting machine is not compromised on speed. A modern fibre laser can be operated at full speed with protected sheets. The films ensure an extremely smooth, burr free cut and effectively eliminate traces of melted material that may result from the cutting process. The films easily cope with additional stresses caused by downstream forming processes such as bending and

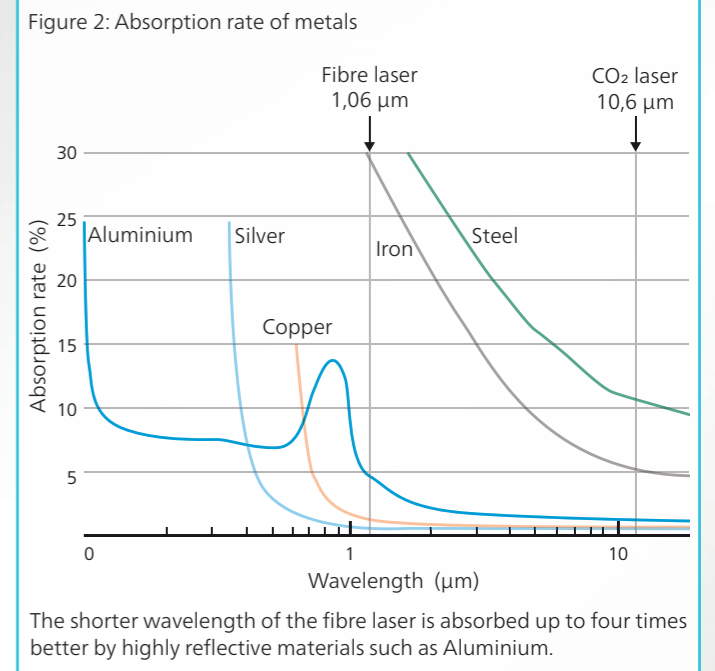

forming. They withstand breakages ensuring the surface remains perfectly protected during the entire production process whilst providing six months UV protection in external environments. As they are PE-based, they are fully recyclable too.

On the following pages you will find an overview of our laser protection films, with a detailed description of the different POLIFILM PROTECTION solutions.

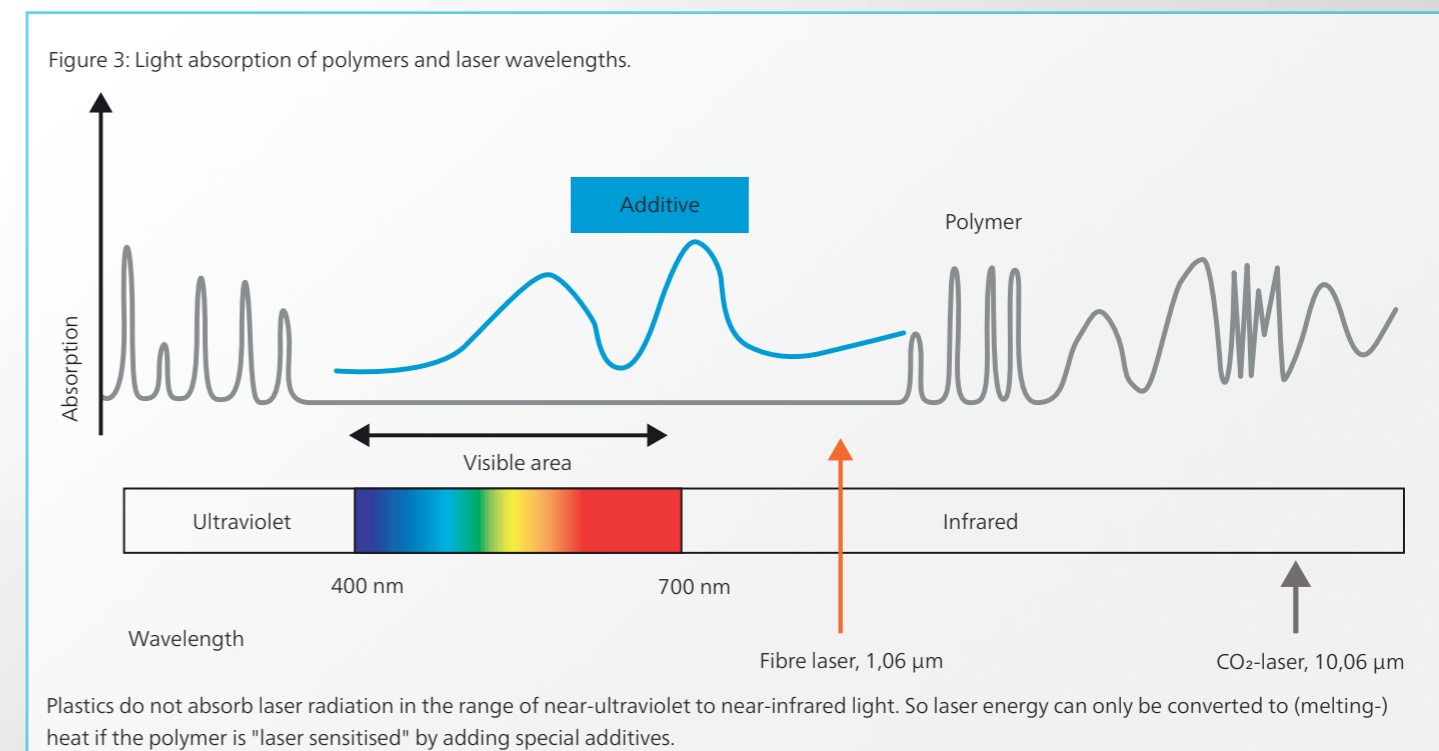



PF584CS 100% EFFICIENT

THE UNIVERSAL SOLUTION

THE GREAT ALL-ROUNDER OPTIMUM PROTECTION WITH MAXIMUM EFFICIENCY

Amongst protective films, PF584CS is the true all-rounder. It is used on CO₂ and fibre lasers alike. This multipurpose protection film delivers exceptional performance for perfect results every time, making rejections a thing of the past. Behind the outstanding performance of this proven film, there is a refined composition. The polyethylene carrier film is specifically engineered for laser cutting with a precisely matched natural rubber based adhesive formulation. With stringent quality assurance standards, together this ensures a Universal Laser Film solution that provides all round protection to high quality finishes during laser cutting and beyond. The film ensures the integrity of the surface finish in each and every subsequent process that follows.

SAFE AND EFFECTIVE LASER CUTTING

Flexibility made easy.

Two technologies, one film. Compatible with both CO₂ and fibre lasers; PF584CS can simplify complex processes in both warehousing and processing.

No pre-cutting. More time. Less Cost.

Shortened production times are achieved through no pre-cutting of the film. PF584CS is cut simultaneously with the material.

No bubbling.

With its extremely reliable adhesion system, PF584CS offers all-round protection throughout the entire laser cutting process. The adhesive is specially formulated to prevent the film from bubbling from the pierce point through to the final cut.

A smooth operator.

PF584CS guarantees smooth, burr free cut edges with no traces of soot. There is no need for costly and time consuming reworking associated with cleaning.

Quality from start to finish.

One quality factor of a protective film is the way it peels off after processing. It should remove easily, cleanly and without tearing. PF584CS exceeds expectations for ease of removability without any need for cleaning once removed.

Always in shape.

You can confidently put PF584CS through its paces. Subsequent processes present little challenges where the sheet may be bent, formed or stamped. PF584CS excels with outstanding flexibility and elasticity ensuring there is no tearing at all times.

- ✓ Available in 2 film thicknesses.
- ✓ Reliable adhesion. No bubbling.
- ✓ Excellent cutting. No burrs. No traces of soot.
- ✓ Easy and clean removal. No tearing.
- ✓ Functional print.
- ✓ 6-month UV resistance.
- ✓ Fully recyclable PE film.

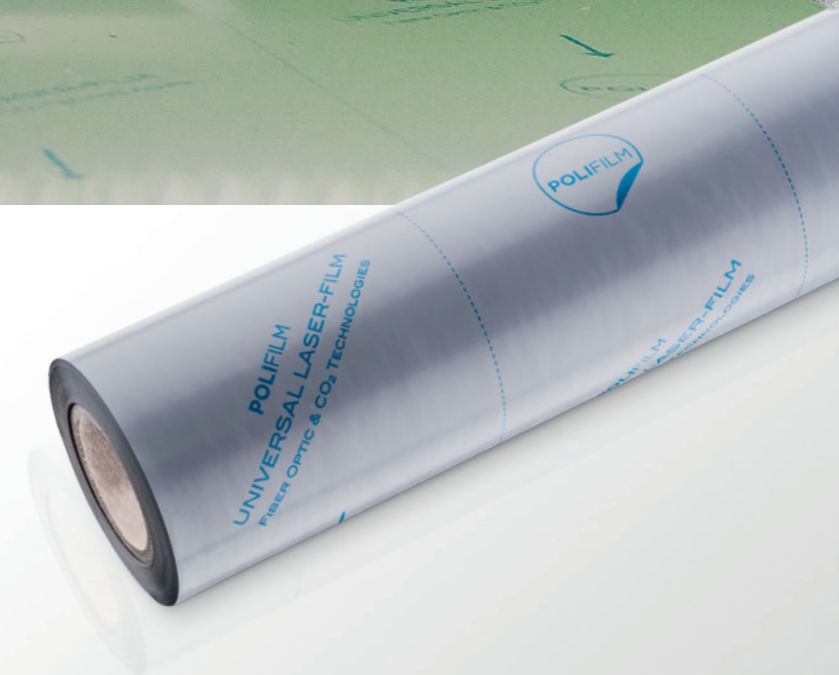

PF582CS, PF32CS, PF82CS 100% RISK FREE REMOVAL

THIN METAL SHEETS

Thin sheets are easy to shape and work well with a laser. However, due to their thinness, they are susceptible to undesired bending especially when the protective film is removed. POLIFILM PROTECTION has therefore developed a range of special laser protection films with tailor-made properties **for sheets up to 0.8 mm thick**

- ✓ Precisely adjusted adhesion. Easy removal. No bending.
- ✓ Optimum unwinding properties.
- ✓ Residue-free removal. No tearing.
- ✓ Excellent cutting. No burrs. No traces of soot.



PF84CS 100% SPEED

FOR FIBRE LASER

THE INNOVATIVE FIBRE LASER SOLUTION OPTIMUM CUTTING QUALITY WITH MAXIMUM SPEED

Thin sheet materials, large production volumes, high power density, the fastest possible processing speeds; this is the world of fibre lasers! If your protective film doesn't match, you will have problems.

In performance environments like this, conventional laser films often block the process, at best offering poor cutting quality, resulting in the fibre laser machine being slowed down to cope with the inferior performance of the film. PF84CS is different. Thanks to its unique film formulation, it fully absorbs the laser beam. The result: 100% absorption of the laser beam. 100% speed. 100% cutting quality. No limit, no matter how fast you go!

PERFORMANCE AND QUALITY GUARANTEED.

Full power, no limit.

A unique feature of PF84CS is its individual absorption property allowing unrestricted energy transfer in the cut ensuring the fibre laser can operate at full speed. The base material along with the protective film are processed in a single motion eradicating the need for timely pre-cutting. Despite the difficulties of laser cutting highly reflective materials like polished Aluminium, PF84CS does an amazing job. It significantly improves the level of absorption and optimises the cutting process throughout.

Outstanding quality.

Even with the most demanding cutting geometries, at full speed PF84CS delivers consistently unrivalled cutting quality. The cut edges are clean, smooth and burr free. The outstanding quality of the component is guaranteed, as there is no need for time consuming reworking, waste is avoided and costs are controlled. A key feature of the POLIFILM PROTECTION laser films are their excellent removal properties. They can be removed safely and easily without the need for additional cleaning operations.

Less contamination. Highest productivity.

With PF84C, laser nozzles stay much cleaner than conventional laser films allow. A fact that has been proven with extensive testing with renowned laser cutting machine manufacturers. This leads to significantly improved productivity as downtime through cleaning is minimised.

Maximum protection at all times.

Thanks to the highly engineered adhesive formulation, PF84CS Universal Laser Film demonstrates excellent adhesion and offers reliable and dependable protection throughout the entire laser cutting process. Bubbling is eradicated from the first incision and throughout the cutting operation. PF84CS also effortlessly withstands the demands placed on it by forming, bending or punching. It resists tearing ensuring a flawless finish throughout production processing, manufacturing and other associated operations.

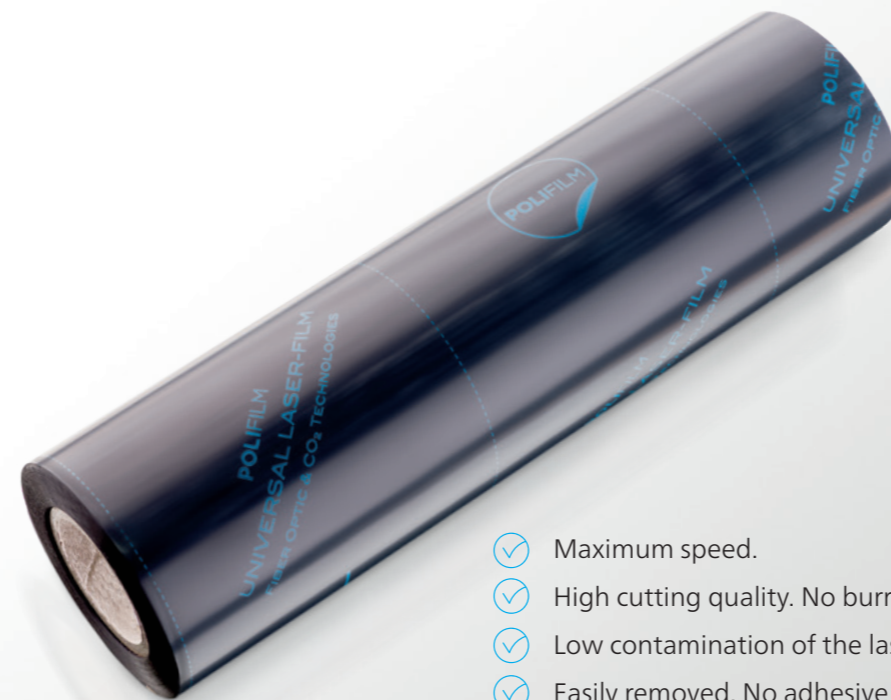

High-speed protection for the fibre laser.

- ✓ Maximum speed.
- ✓ High cutting quality. No burrs. No traces of carbon.
- ✓ Low contamination of the laser nozzle.
- ✓ Easily removed. No adhesive residue. No tearing.
- ✓ 6-month UV resistance.
- ✓ Functional print.
- ✓ Can also be used on CO₂ lasers.
- ✓ Fully recyclable PE film.

PF34CS 100% TRANSPARENCY

THE INNOVATION FOR FIBRE LASER

THE UNIQUE FILM SOLUTION FULL TRANSPARENCY MAXIMUM PROTECTION

Fibre lasers are becoming increasingly popular for cutting Stainless Steel, structured metals and coated or pre-painted sheets. However, there has never been a protection film for fibre lasers that maintains high quality surface finishes whilst allowing immediate visual quality inspection during the production process. Until now! POLIFILM PROTECTION now provides the solution. The highly transparent PF34CS offers the unique solution for laser applications. Excellent protective properties combined with the benefit of unrestricted visual inspection throughout the entire production process.

COMPLETE TRANSPARENCY

Simple quality inspection. Before, during and after.

Previously, surface quality checks were only possible at the end of a production run where the protection film had to be removed.

Our transparent laser protection film PF34CS, enables operators to perform a quality check at any time during the process. This brings two distinct advantages: firstly, there is no need to peel off the protection film in order to check, leaving the surface securely protected at all times. Secondly, any surface related issues can be detected immediately, thus saving time, ensuring optimal quality and reducing rejection rates.

Surface finish assured.

The direction of a polish and pattern is clearly visible at all times. In the case of pre-painted sheets, colours are identified immediately. PF34CS prevents costly mix ups in the finishing process and simplifies goods inwards inspections.

Optimum protection. Optimised aesthetics.

Thanks to its specially formulated rubber based adhesive, PF34CS offers reliable adhesion without peeling around edges, holes and intricate cut designs. As the film is transparent, PF34CS cannot leave black carbon residues at the

cutting edge eliminating the need for additional costly cleaning processes. The result: Excellent cutting quality, process efficiency and optimum protection of high quality finishes both during and after processing.

Excellent removal properties.

As part of the POLIFILM PROTECTION range of laser films, PF34CS offers excellent removal properties. It can be removed after the entire production process in one piece without the risk of residue and without tearing.

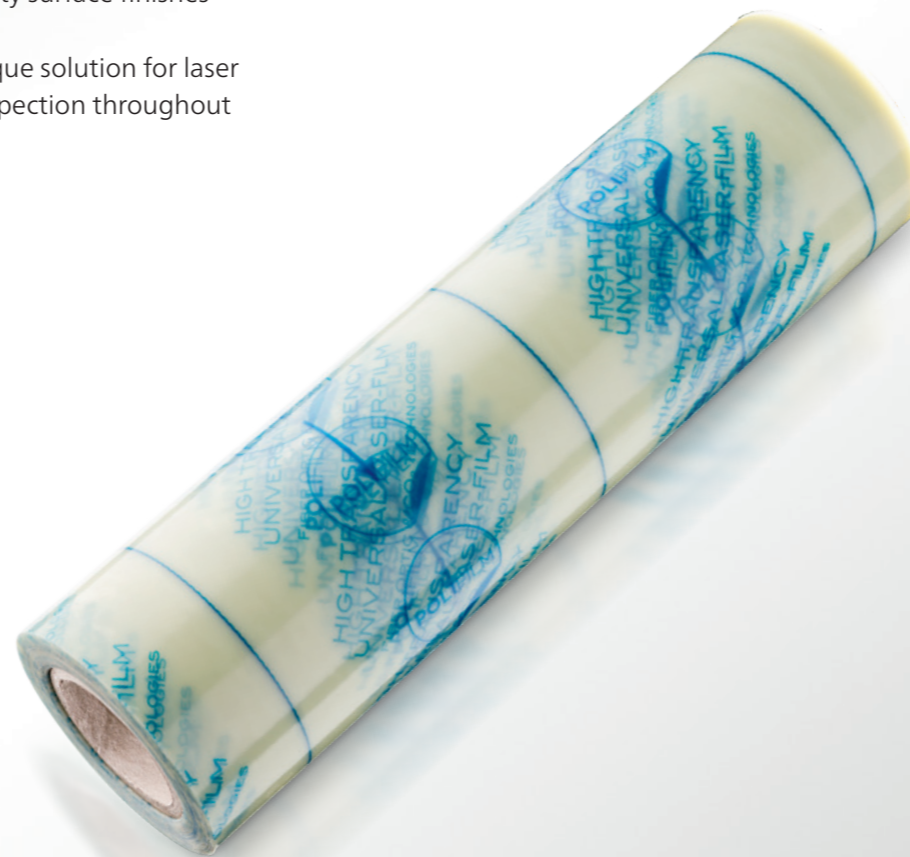

Perfect removal properties, no adhesive residue, no traces of soot.

- ✓ First highly transparent fibre laser suitable protective film.
- ✓ Reliable adhesion. No bubbling.
- ✓ High cutting quality. No burrs. No traces of soot.
- ✓ Easily removed. No adhesive residue. No tearing.
- ✓ Functional print.
- ✓ Can also be used on CO₂ lasers.
- ✓ Fully recyclable PE film.

OPTIMUM PROTECTION POLIFILM PROTECTION FILM SOLUTIONS

FOR LASER CUTTING OF STAINLESS STEEL AND ALUMINIUM

POLIFILM PROTECTION laser films slot seamlessly into your laser cutting processes. They help you to deliver outstanding quality products to your customer. Your high quality finishes are fully protected during the entire laser cutting process and beyond. Our protection films ensure the complete integrity of your product

throughout any finishing process. Whether CO₂ or fibre laser, Stainless Steel or Aluminium, structured or smooth surfaces – POLIFILM PROTECTION laser protection films cover them all. The perfect solution for every situation.



PROTECTIVE FILMS FOR CO₂ AND FIBER LASER

FILM CHARACTERISTICS							SURFACES	
PRODUCT TYPE*	MATERIAL	ADHESIVE TYPE	ADHESIVE STRENGTH	FILM THICKNESS	COLOUR	UV- RESISTANCE**	STAINLESS STEEL	ALUMINIUM
PF84 C S	Polyethylene	Natural Rubber	High	100 µm	Black Grey	6 Month	All Types of Finish	Mill-Finish Anodized
PF82 C S	Polyethylene	Natural Rubber	Medium	80 µm	Black Grey	6 Month	Thin, High Glossy Sheets	Thin, Bright Polished
PF584 C S	Polyethylene	Natural Rubber	High	80 100 µm	Black Light Grey	6 Month	All Types of Finish	Mill-Finish Anodized
PF584 C S BIOBASED***	Polyethylene	Natural Rubber	High	80 100 µm	Black Light Grey	6 Month	All Types of Finish	Mill-Finish Anodized
PF582 C S	Polyethylene	Natural Rubber	Medium	60 80 µm	Black Light Grey	6 Month	Thin, High Glossy Sheets	Thin, Bright Polished
PF581 C S	Polyethylene	Natural Rubber	Low	75 µm	Black Light Grey	6 Month	Thin, High Glossy Sheets	Thin, Bright Polished
PF34 C S	Polyethylene	Natural Rubber	High	80 µm	Transparent	–	All Types of Finish	Mill-Finish Anodized
PF32 C S	Polyethylene	Natural Rubber	Medium	80 µm	Transparent	–	Thin, High Glossy Sheets	Thin, Bright Polished

* Suitable for CO₂ & Fibre Laser | ** UV-resistance according to Western European climate | *** BIOBASED: 20% content – produced according to mass balance approach

PROTECTIVE FILMS FOR CO₂ LASER

FILM CHARACTERISTICS							SURFACES	
PRODUCT TYPE	MATERIAL	ADHESIVE TYPE	ADHESIVE STRENGTH	FILM THICKNESS	COLOUR	UV- RESISTANCE*	STAINLESS STEEL	ALUMINIUM
PF564 C	Polyethylene	Natural Rubber	High	80 100 µm	Black White	12 Month	All Types of Finishes	Mill-Finish Anodised
PF563 C	Polyethylene	Natural Rubber	High	80 100 µm	Black White	12 Month	All Types of Finishes	Mill-Finish Anodised

*UV-resistance according to Western European climate



YOUR VALUES. OUR PROTECTION. POLIFILM PROTECTION

FAMILY-OWNED. GLOBALLY RECOGNISED.

YOUR PARTNER FOR TEMPORARY SURFACE PROTECTION FILM SOLUTIONS

When carrier film expertise is combined with specialised adhesive systems, when customers' applications and manufacturing processes are the focus, the results are tailor-made solutions for temporary surface protection featuring exceptional benefits.

POLIFILM PROTECTION has been delivering high quality temporary protection film solutions for over 40 years. Protection that is expertly designed, highly effective which creates real added value. Protection that will take your products safely through production processing, manufacturing and other associated operations delivering satisfaction throughout.

Knowing what's important in protection and service.

As a process partner and specialist in co-extrusion, adhesive development and coating, within our wide range of self-adhesive and adhesive coated film solutions, we will find the ideal protection film for your needs. Understanding our customers demanding technological processes with differing surface materials is just as much part of our day-to-day business as providing excellence in service. Local presence, market leading flexibility, assured product availability and immediate delivery are integral to our service and a direct result of our global philosophy.

POLIFILM PROTECTION is part of the family owned internationally represented POLIFILM Group: A leading manufacturer of polyethylene based film solutions. No matter where you are located, with our global network of production, sales and distribution locations, our continuously evolving expertise is always on hand.

Expertise in films. Expertise in adhesives. Expertise in the ideal protective solutions.

A protection film is only as good as the interaction of its components. We maintain our quality standards by using only the highest functionality in carrier films and adhesives. We use three distinct adhesive systems: Firstly, our own Natural Rubber adhesive which is made in-house, secondly, our Water based Acrylic adhesive and finally our Solvent based Acrylic adhesives; all of which enable us to cover each and every application. Our carrier films and their adhesive systems are precisely selected and matched to create a film with properties that meet the requirements of the finished product and the demands of the production process.

Protection solutions for every imaginable task.

Are you looking for film solutions that go beyond laser cutting? No problem! At POLIFILM PROTECTION we have specifically designed protection films for every application covering an extensive range of industries.

- ✓ Stainless Steel
- ✓ Aluminium
- ✓ Pre-Painted Metal
- ✓ Plastic Plates / Profiles
- ✓ Glass
- ✓ Carpets
- ✓ Laminates



GERMANY

POLIFILM PROTECTION
DEUTSCHLAND GMBH & CO. KG
Handelsstraße 12
D-42929 Wermelskirchen
T: +49 2196 88 20 80
F: +49 2196 8 82 08 99
Email: info-pfp@polifilm.de
www.polifilm.de

ITALY

POLIFILM ITALIA S.R.L
Via Filippo Brunelleschi, 7
IT-44020 San Giovanni di
Ostellato (FE)
T: +39 0533 5 73 69
F: +39 0533 5 75 42
Email: info@polifilm.it
www.polifilm.com

FRANCE

POLIFILM FRANCE SAS
ZA la Condamine,
2 chemin des senteurs
FR-26400 Aouste sur Sye
T: +33 475 25 41 44
F: +33 475 40 68 93
Email: info@polifilm.fr
www.polifilm.fr

SPAIN

POLIFILM PROTECCIÓN
IBÉRICA S.A.
Polig. Ind. Ca n' Oller
c/ Valencia, 17-19 Nave 3
ES-08130 Santa Perpetua De Mogoda
(Barcelona)
T: +34 9371 9 43 43
F: +34 9371 8 18 74
Email: info@polifilmiberica.es
www.polifilm.com

UNITED KINGDOM

POLIFILM UK LIMITED
7 Brunel Close
Drayton Fields Industrial Estate
GB-Daventry NN11 8RB
T: +44 1327 87 60 71
F: +44 1327 30 00 05
Email: sales@poli-film.co.uk
www.polifilm.com/uk

TURKEY

POLIFILM PROTECTION
TURKEY PLS. SAN. TIC. LTD. ŞTI.
Barbaros Mah. Mor Sümbül Sok. No. 5
Kat. 7 Daire 211 Deluxia Palace
TR-Batı Ataşehir / Istanbul
T: +90 2165 10 10 80
Email: info@poli-film-turkey.com
www.polifilm.com

AMERICA HEADQUARTER | MIDWEST

POLIFILM AMERICA INC.
One Elgiloy Drive
US-IL 60140 Hampshire
T: +1 8476 83 14 14
F: +1 8476 83 77 77
Email: info@polifilm.us
www.polifilmamerica.com

AMERICA NORTHEAST

POLIFILM AMERICA INC.
Keystone Drive 170,
US-PA 18936 Montgomeryville
T: +1 2156 43 62 30
F: +1 2156 83 62 53
Email: info@polifilm.us
www.polifilmamerica.com

AMERICA SOUTHEAST

POLIFILM AMERICA INC.
300 TownPark Dr NW, Suite 140
US-GA 30144 Kennesaw
T: +1 6782 90 17 78
F: +1 6782 90 17 58
Email: info@polifilm.us
www.polifilmamerica.com

MEXICO

POLI-FILM MEXICO
S. DE R.L. DE C.V.
Carretera Miguel Aleman
Km14.2 Bodega 10
MX-Apodaca NL 66630
T: +11 5281 10 86 18 00
F: +11 5281 10 86 18 01
Email: ventas@polifilm.mx
www.polifilmamerica.com

ISRAEL

POLEG PLASTICS INDUSTRIES
(1998) LTD
Kibbutz Gevim
D.N HOF Ashkelon
IL-7916500
T: +972 8680 23 60
F: +972 8680 21 63
Email: info@polegpf.com
www.polifilm.com

CHINA

POLI-FILM SHANGHAI CO. LTD
Room 2105-2106, Zhonggong Global
Creative Center T2,
Lane 166 Minhong Road,
CN-Minhang District, Shanghai
T: +86 21 51099518
F: +86 21 54376980
Email: sales@polifilm-china.com
www.polifilm.com

AUSTRALIA

POLIFILM AUSTRALIA PTY
LIMITED
9 Sammut Street,
Smithfield
AU - NSW 2164
T: +61 2 9729 0857
F: +61 29609 2375
Email: duncan@polifilm.com.au
www.polifilm.com.au

SOUTH AFRICA

POLIFILM SOUTH AFRICA
(PTY) LTD
Culverwell Park
139 Houtbaai street
Elandshaven EXT 4
ZA-1401 Germiston
T: +2711 7 08 10 41
F: +2711 8 69 16 68
Email: reception@polifilm.co.za
www.polifilm.com

OPTIMUM PROTECTION DELIVERED TO YOU

FROM OUR GLOBAL NETWORK

Temporary protection film solutions where you need them, when you need them, with all-round service and outstanding quality you expect. This is the mission we live up to each and every day.

Our global network of production locations, sales branches with integrated service and logistics centres alongside more than 20 well established distribution partners, help us to achieve this. POLIFILM PROTECTION is always nearby and able to offer you the global flexibility of our reliable family-owned company.



If your location is not listed, no problem! We are happy to direct you to the right place.

Simply scan the barcode and select your distribution partner, otherwise please contact POLIFILM PROTECTION GMBH at info-pfp@polifilm.de, Phone +49 2267 697 0, Fax +49 2267 697 4101 and allow us to do the rest, then we'll be in touch.



POLIFILM PROTECTION GMBH

Alte Papiermühle Hämmern 10
51688 Wipperfürth
Germany

Member of the POLIFILM Group

Tel. +49 (0) 2267 697 0
Fax +49 (0) 2267 697 4101
Email: info-pfp@polifilm.de

www.polifilm.com